

58.312

Viewlite plus monitor arm - wall 312

Free up desk space with this wall-mounted monitor arm. It's easy to use and with the swivel limiter, which reduces the chance of bumping into walls or desks, you can locate it pretty well anywhere. Cables are easily hidden in the arm's aluminium extension to create a tidy, professional impression.

- Dynamic height adjustment range of 240 mm (9,4")
- Dependent depth adjustment
- Integrated cable management
- Main components made of aluminium
- 40% of aluminium content is already recycled
- VESA MIS-D 75 x 75/100 x 100 mm compatible
- Monitor: tilt +90°/-55°, swivel +90°/-90°, rotate 360°
- Arm: swivel +90°/-90°
- Weight capacity min. 0 kg - max. 7 kg (0 - 15,4 lb) per monitor
- Comes with a wall mount
- Fitted with a practical quick-release VESA system
- Monitor rotation lock can be enabled
- Swivel limiter pre-set to +90°/-90° (can be disabled)

viewlite X

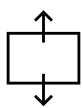
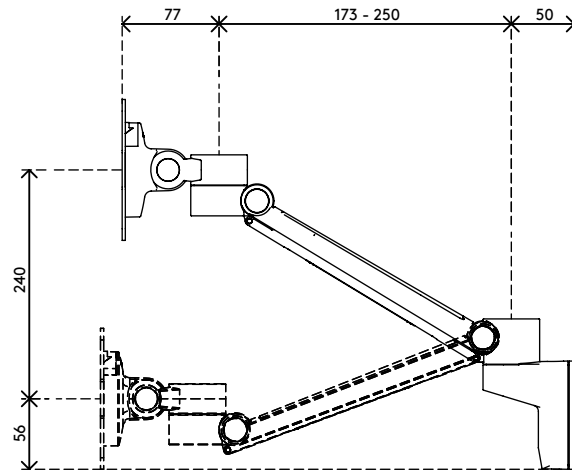
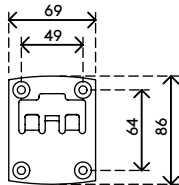
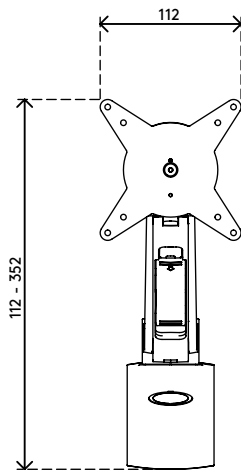
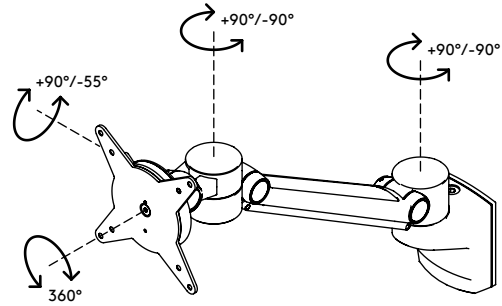
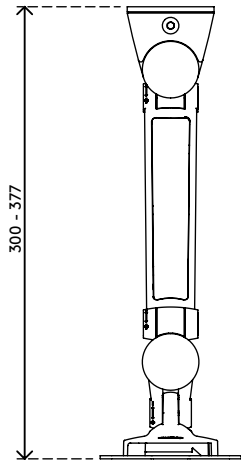

240 mm (9,4")



+90°/-55°

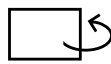

+90°/-90°



360°



75 x 75/100 x 100



0 - 7 kg (0 - 15,4 lb)

Viewlite plus monitor arm - wall 312

2020/10/06

58.312

 477 x 153 x 145 mm

 1 pcs

 silver-white

 2,15 kg

 805410583125