

Contour Laptop Riser

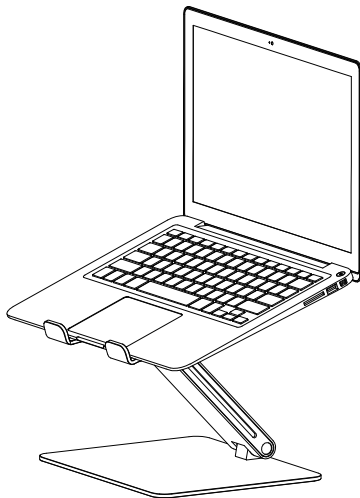

www.contourdesign.com



What's In The Box

Contenu de l'emballage

Packungsinhalt

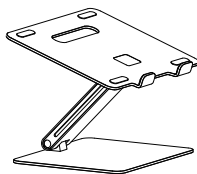

Laptop Riser

Laptop Riser

Laptop-Riser



Adjustment Tool

L'outil d'ajustment

Einstellwerkzeug

***Please visit www.contourdesign.com to view product manuals available in local languages.**

*Veuillez visiter www.contourdesign.fr pour consulter les manuels de produits disponibles dans la langue de votre pays.

*Bitte besuchen Sie www.contourdesign.de, um Produkthandbücher in den lokalen Sprachen anzuzeigen.

Usability

Facilité d'utilisation
Benutzerfreundlichkeit

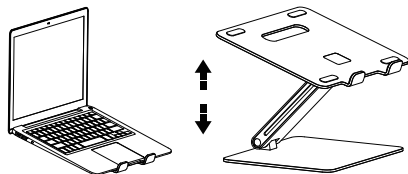

Made for 11-15.6" Laptops

Conçu pour les ordinateurs portables
de 11 à 15,6 pouces

Für 11-15,6-Zoll-Laptops

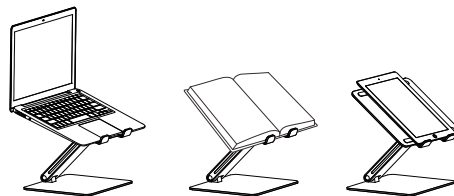

Compatible with the majority of laptops,
books and tablets

Compatible avec la majorité des ordinateurs portables
et tablettes.

Kompatibel mit der Mehrzahl der Laptops, Bücher und
Tablets.

Angle Adjustment

Réglage de l'angle
Winkeleinstellung

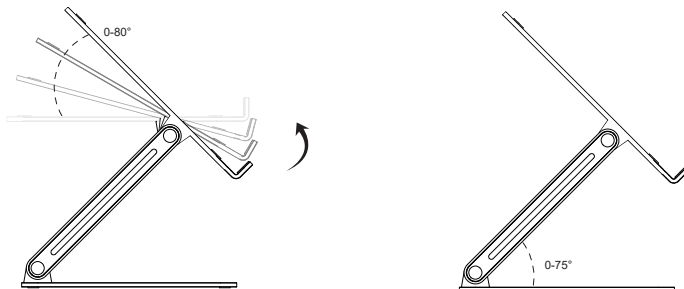

4



Friction Adjustment

! If the Laptop Riser feels too tight or too loose when in use, follow the steps below.

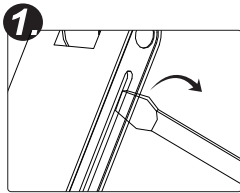

Remove one of the side covers as illustrated in picture 1 and 2.

(e.g. using a flat screw driver)

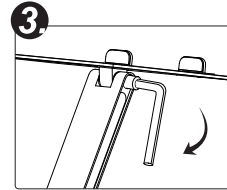
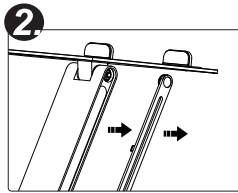

Adjust the screws with the included adjustment tool as shown in pictures 3 and 4, for desired friction.

Put the side covers back in place.

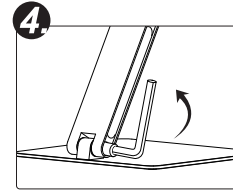

Réglage du frottement

! Si le Laptop Riser semble trop serré ou trop lâche lors de son utilisation, suivez les étapes ci-dessous.

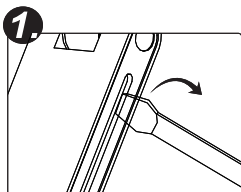

Retirez l'un des couvercles latéraux comme illustré sur les photos 1 et 2.

(par exemple, à l'aide d'un tournevis plat)

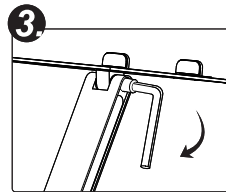
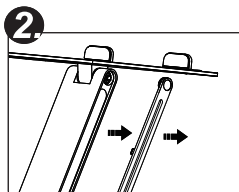

Ajustez les vis à l'aide de l'outil d'ajustement fourni, comme indiqué sur les photos 3 et 4, pour obtenir le frottement souhaité.

Remettez les encoches latérales en place.

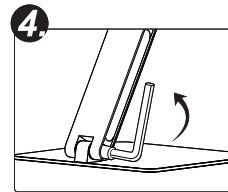

Reibungseinstellung

! Wenn sich der Laptop-Riser bei der Verwendung zu eng oder zu locker anfühlt, befolgen Sie die folgenden Schritte:

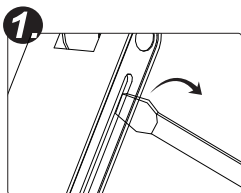

Entfernen Sie eine der Seitenabdeckungen wie in Bild 1 und 2 dargestellt.

[z. B. mit einem flachen Schraubendreher]

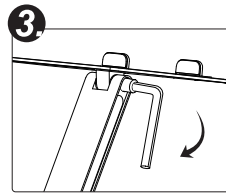
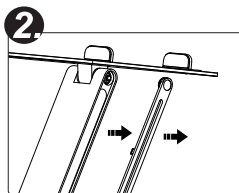

Stellen Sie die Schrauben mit dem mitgelieferten Einstellwerkzeug wie in den Bildern 3 und 4 gezeigt auf die gewünschte Reibung ein.

Setzen Sie die Seitenabdeckungen wieder ein.

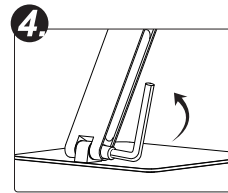

Height Adjustment

Réglage de la hauteur
Höheneinstellung

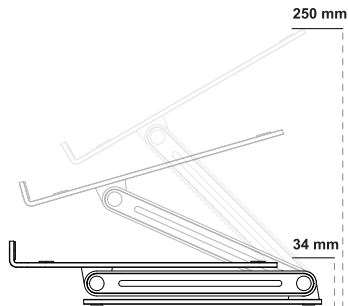



Adjust the height of the Contour Laptop Riser for the laptop screen to reach eye level.

Réglez la hauteur du Contour Laptop Riser pour que l'écran de l'ordinateur portable atteigne le niveau des yeux.

Stellen Sie die Höhe des Contour Laptop Riser so ein, dass der Laptopbildschirm auf Augenhöhe ist.

Warning

Avertissement
Warnung

-  Make sure the Contour Laptop Riser is placed on a flat and stable surface to avoid risk of damage.
-  Assurez-vous que le Laptop Riser de Contour est placé sur une surface plane et stable pour éviter tout risque de dommage.
-  Stellen Sie sicher, dass der Contour Laptop Riser auf einer ebenen und stabilen Oberfläche steht, um Beschädigungen zu vermeiden.



2-year Warranty

All Contour Design products come with a **2-year Warranty**.

2 Jahre Garantie

Sämtliche Produkte von Contour Design verfügen über eine Garantie von zwei Jahren.

Garantie de 2 ans

Tous les produits Contour Design bénéficient d'une garantie de 2 ans

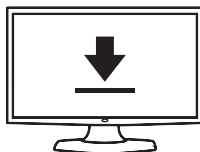

Product Support

For information on software drivers, product manuals, and advanced product settings such as thin client mode, please visit: contourdesign.com/support

Produktsupport

Informationen über Treiber, Bedienungsanleitungen und erweiterte Einstellungen wie den Thin-Client-Modus für unsere Produkte erhalten Sie unter.

Assistance produit

Pour toute information concernant les pilotes, manuels et réglages avancés, tels que le mode « client léger », rendez-vous sur le site.



Sales Support

If you have questions about your recent purchase, email us: United States: ergoinfo@contourdesign.com
All other countries: support@contour-design.com

Vertriebssupport

Wenn Sie Fragen bezüglich Ihrer kürzlichen Erwerbung haben, schicken Sie uns eine E-Mail an: support@contour-design.com

Assistance commerciale

Pour toute question concernant votre achat récent, envoyez-nous un e-mail à l'adresse suivante: support@contour-design.com

