

Power10[®] Elliptical Rower

**FASTER, BETTER
RESULTS WITH
TEETER SUPPORT
& COACHING**



ASSEMBLE FASTER

Free BILT app puts easy 3-D instructions at your fingertips. Search 'Teeter Power10' in BILT to get started.



REACH YOUR GOALS

Access on-demand, trainer-led programs with the free Teeter Move™ app for fun, challenging and effective workouts.



GET SUPPORT

Easily access support through the Video Portal to get the most from your Power10.



NEED HELP? CONTACT US.

 Phone: 800-847-0143

 Email: info@teeter.com

 Live Chat: teeter.com



WELCOME TO THE TEETER FAMILY

Congratulations on your purchase of the Teeter Power10™!
For the best experience, it is critical that you follow, read, and fully understand the Assembly & Use Instructions. The Power10 is a multiple user, reusable device for home use, intended to provide a comfortable, free-motion strength training workout for adults.

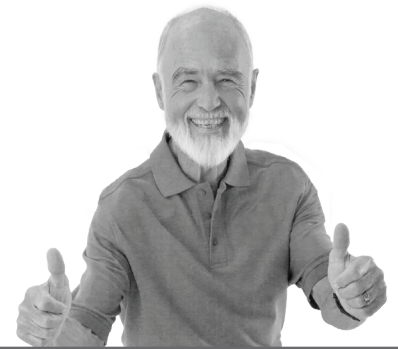

“I created Teeter so people could live healthier and more active lives.”
-Roger Teeter

We've Got Your Back!



If you have any questions concerning assembly or if any parts are missing, **DO NOT RETURN THE ITEM TO THE STORE OR CONTACT THE RETAILER.** Our dedicated product service experts can help! Contact Teeter Customer Service at **800-847-0143**, or via online forms or Live Chat at **teeter.com**.



Trust Teeter for unmatched quality and performance, backed by our industry-leading warranty coverage. To register your product warranty, go to **teeter.com/warranty**.

TABLE OF CONTENTS

Assembly Instructions

Important Safety Instructions	1
Items for Assembly	2
Understanding Your Power10.....	3
Safety Warning Labels & Product Specifications.....	4
Assembly Steps.....	5 – 15

User Guide

Console Use	16-17
Storage	17
User Adjustments	18
Rowing Direction	19
Muscle Targeting	20
Warranty and Registration	21

BEFORE YOU BEGIN: Review all steps before beginning assembly and read all precautions before using the Teeter Power10™. Carefully adhere to the Assembly Instructions and User Guide to help ensure safety and product integrity.

IMPORTANT SAFETY INSTRUCTIONS

READ ALL INSTRUCTIONS BEFORE USING THE TEETER POWER10™

WARNING

FAILURE TO FOLLOW INSTRUCTIONS AND WARNINGS COULD RESULT IN SERIOUS INJURY OR DEATH.

To reduce the risk of injury:

- Read and understand all the instructions, review all other accompanying documents, and inspect the equipment before use. It is your responsibility to familiarize yourself with the proper use of this equipment and the inherent risks of exercise equipment if these instructions are not followed, such as, pinching, entrapment, equipment failure, or aggravating a pre-existing medical condition. It is the responsibility of the owner to ensure that all users of the product are fully informed about the proper use of the equipment and all safety precautions.
- **ALWAYS** consult with your doctor before beginning any exercise or weight-loss program, especially if you are over the age of 35 or have any known pre-existing medical problems. This may include injury or illness, but also the side effects of any drug or supplement (prescribed or over-the-counter).
- The instructions and advice presented in this User Guide are in no way intended as a substitute for medical advice or counseling.
- **DO NOT** continue using the equipment if you feel pain, discomfort, shortness of breath, chest tightness, or become light-headed or dizzy while exercising. STOP and seek medical advice. Call 911 if you are having an emergency health condition.
- **DO NOT** use if you are over 300 lbs. (136 kg). Structural failure and physical injury could occur.
- **ALWAYS** ensure that all adjustable features are accurately adjusted to the users' body proportions and all parts are fully tightened and secured before use. **ALWAYS** secure both feet to the Foot Platform with the Foot Straps when in use. **ALWAYS** hold the Handles when mounting or dismounting.
- **DO NOT** place hands or feet near linkages while in use. The linkages are flywheel driven and can cause serious injury, entrapment, or death. **DO NOT** allow pets or children to approach the linkage while it is moving.
- **DO NOT** place any objects within a 24" (61 cm) radius of the machine. Do not place any objects or body parts behind the pivot area Rear Linkage Assembly or Handles.
- **ALWAYS** reduce rowing speed in a controlled manner. Handles and Seat continue to move when you stop rowing.
- **ALWAYS** set the resistance level to the maximum while not in use to prevent unintentional movement of the equipment.
- **DO NOT** allow children to use this machine. Keep children, bystanders, and pets away from machine at all times and **DO NOT** allow children to be left unattended in the same room as the equipment. The equipment is not intended for use by persons with reduced physical, sensory or mental capabilities, unless they are given supervision and instruction concerning use of the machine by a person responsible for their safety.
- **ALWAYS** wear appropriate clothing while exercising with the machine. **DO NOT** wear loose clothing that could get entangled in the equipment. **ALWAYS** wear athletic shoes to protect feet while exercising with the machine.
- **ALWAYS** store indoors and on a level surface. This equipment is not intended for outdoor use.
- **DO NOT** use in any commercial, rental or institutional setting. This product is intended for home-use only.
- **ALWAYS** use this equipment only for its intended use as described in this manual. **DO NOT** use attachments not recommended by manufacturer.
- **DO NOT** drop or insert any object into any opening or place any sharp objects near the equipment. Keep body parts, hair, loose clothing and jewelry clear of all moving parts.
- **DO NOT** operate equipment while under the influence of drugs, alcohol, or medication that may cause drowsiness or disorientation.
- **ALWAYS** inspect the equipment prior to use. Make sure all fasteners are secure and adjustable settings are secure.
- **ALWAYS** replace defective components immediately and/or keep the equipment out of use until repaired.
- **ALWAYS** position equipment on a level surface and away from water or ledges that could lead to accidental immersion or falls.
- **ALWAYS** use a damp cloth when cleaning. **DO NOT** use abrasive soaps or solvents to clean as this could cause damage to the machine.
- Refer to additional warning notices posted on the equipment. If a product label or User Guide should become lost, damaged or illegible, contact Customer Service for replacement.

SAVE THESE INSTRUCTIONS

ITEMS FOR ASSEMBLY

Items not shown to scale. Hardware drawings located on the Hardware Kit insert.

ITEM NO.	ITEM NAME
Base Assembly	
XR1101	Base with Upper Left Handle
XR2102	Rear Linkage
XR1101A	Fork Joint Cover
HK1056	Step 1 Hardware Kit
HK1057	Step 2 Hardware Kit
HK1058	Step 3 Hardware Kit
HK1061	Step 6 Hardware Kit
HK1065	Step 10 Hardware Kit
Foot Platform Assembly	
XR1106	Foot Platform
XR1106A	Foot Platform Joint Cover
HK1059	Step 4 Hardware Kit
HK1060	Step 5 Hardware Kit
Seat Assembly	
XR2105	Seat
XR2105A	Seat Support
HK1064A, HK1064B	Step 9 Hardware Kits A/B

ITEM NO.	ITEM NAME
Handle Assembly	
XR1104L	Lower Left Handle
XR1104R	Lower Right Handle
XR1103R	Upper Right Handle
HK1062	Step 7 Hardware Kit
HK1063	Step 8 Hardware Kit
HK1066	Step 11 Hardware Kit
HK1067	Step 12 Hardware Kit
Console Assembly	
XR1107	Console
HK1068	Step 13 Hardware Kit
Tools	
XR1129	4mm Allen Wrench
EP1128A	6mm Allen Wrench
XR1130	8mm Allen Wrench
XR1131	Phillips Head Screwdriver

Base with Upper Left Handle

Use with Step 1, 6 & 10 Hardware Kits
(HK1056 / HK1061 / HK1065)

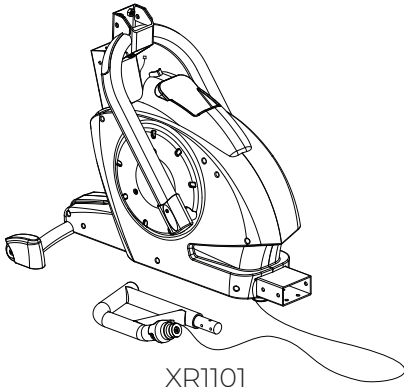

XR1101

Rear Linkage

Use with Step 2 Hardware Kit
(HK1057)

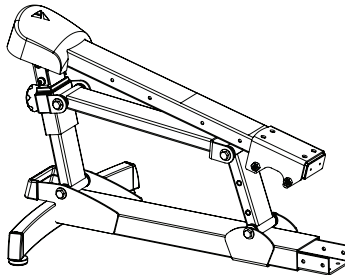

XR2102

Foot Platform

Use with Step 4 Hardware Kit
(HK1059)

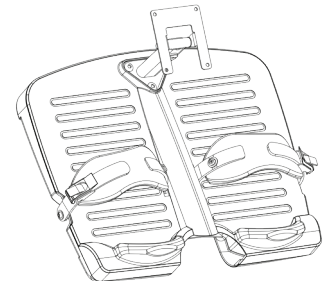

XR1106

Fork Joint Cover

Use with Step 3 Hardware Kit
(HK1058)

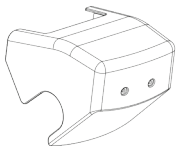

XR1101A

Foot Platform Joint Cover

Use with Step 5 Hardware Kit
(HK1060)

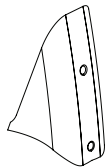

XR1106A

Seat

Use with Step 9 Hardware Kit
(HK1064)

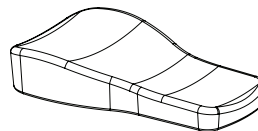

XR2105

Seat Support

Use with Step 9 Hardware Kit
(HK1064)

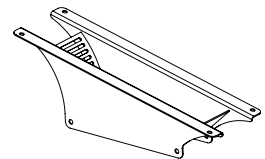

XR2105A

Lower Handles

Use with Step 7, 8 & 11 Hardware Kit
(HK1062 / HK1063 / HK1066)

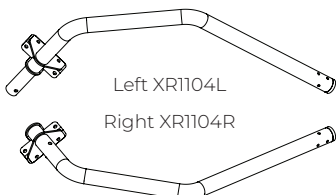

Left XR1104L
Right XR1104R

Upper Right Handle

Use with Step 12
Hardware Kit (HK1067)

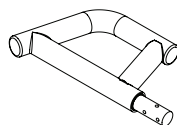

XR1103R

Console

Use with Step 13
Hardware Kit (HK1068)
and Batteries



XR1107

Heart Rate Monitor

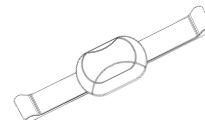

XR1800

Tools

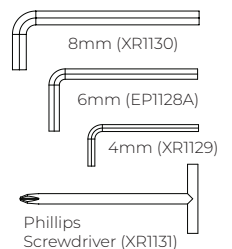

XR1132

UNDERSTANDING YOUR POWER10

Before reading further, study the drawing below to familiarize yourself with the important components of your Teeter Power10.

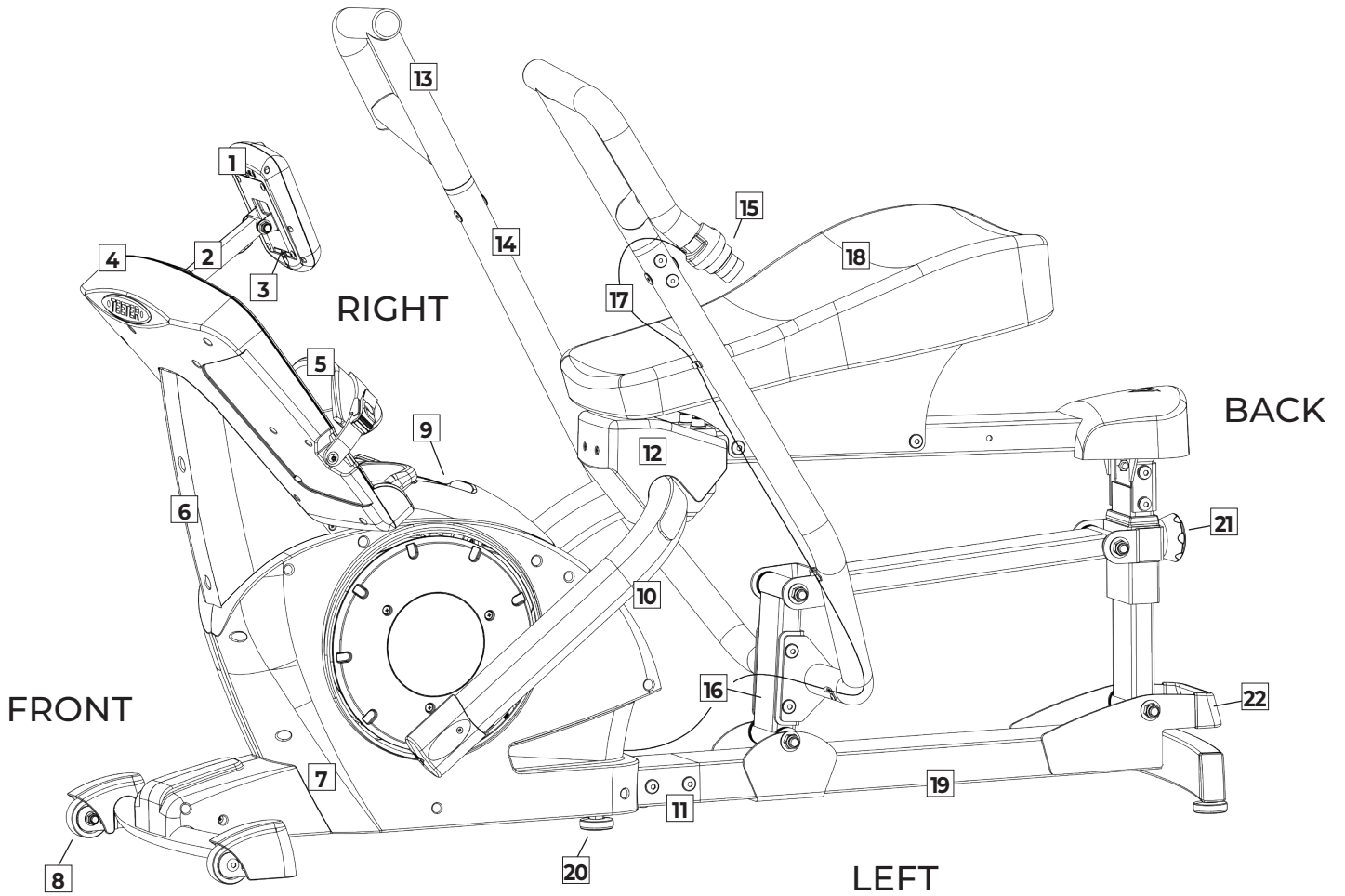

Identifying Parts and Components

1	Console
2	Console Support
3	Battery Compartment
4	Foot Platform
5	Ratchet Strap
6	Foot Platform Joint Cover
7	Base
8	Transport Wheel

9	Media Holder
10	Base Fork
11	Base Joint
12	Fork Joint Cover
13	Upper Handle
14	Lower Handle
15	Resistance Dial
16	Handle Support Bar

17	Cable
18	Seat
19	Rear Linkage
20	Leveling Foot
21	Handle Adjustment Knob
22	Rear Handle

* Specifications may vary from this image and are subject to change without notice.

SAFETY WARNING LABELS & PRODUCT SPECIFICATIONS

IMPORTANT: Please review all labels and supporting materials before using your Power10.

This drawing indicates the locations of the warning labels found on your product. If a label is missing, illegible or is removed, contact Teeter Customer Service to request a complimentary replacement label.

NOTE: Image and labels below not shown at actual size.

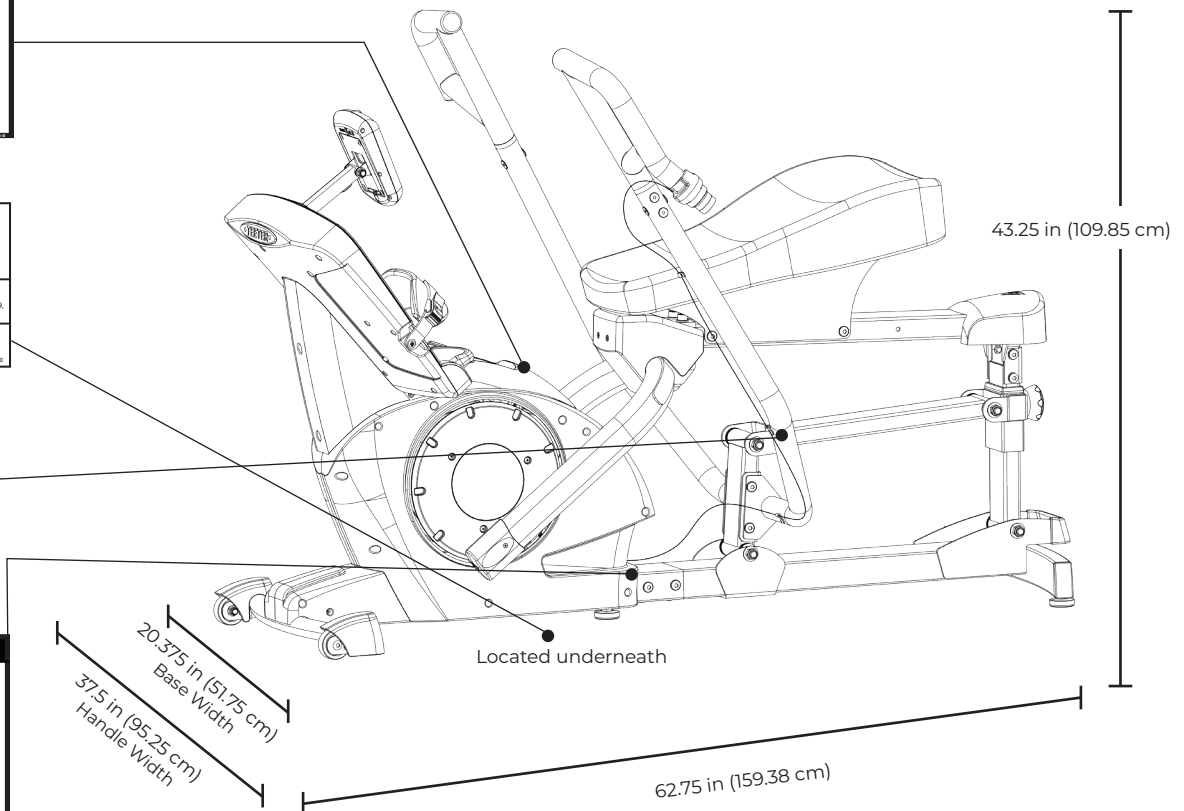
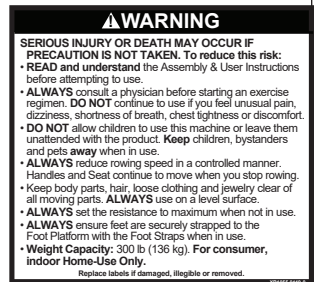
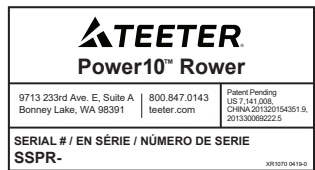

Assembled Non-Use Dimensions:

Base Width: 62.75 x 43.25 x 20.375 in (159.38 x 109.85 x 51.75 cm)

Handle Width: 62.75 x 43.25 x 37.5 in (159.38 x 109.85 x 95.25 cm)

Weight (approx.): 185.0 lb (83.65 kg)

* Specifications may vary from this image and are subject to change without notice.

LET'S GET STARTED

Unpack and Prepare Your Workspace

- If possible, assemble the equipment at or near the space in which you intend to use it to avoid moving it later.
- Unpack all parts and support materials. Set aside packing materials and clear your work area.
- Locate the Hardware Kits packaged with the manuals. They are labeled to correspond with the assembly process.

BASE ASSEMBLY

NOTE: Always hand tighten all hardware in each step before fully tightening with the wrench or screwdriver. The Front, Back, Right and Left of the equipment is labeled in the drawing on Page 3. The Left Upper Handle is attached to the Base with a Cable. Use caution and **DO NOT** pinch or pull on the Cable to avoid damage during assembly.

IMPORTANT: The Rear Linkage has multiple pivot points. Use caution to avoid pinching.

Figure 1: Turn the Leveling Foot at the bottom of the Base counterclockwise to support the Base Joint off the ground. Hold the Rear Linkage with one hand on the Rear Handle and the other hand holding the bottom support bar.

Align the Rear Linkage to the Base and insert at the Base Joint. Adjust the center and rear Leveling Feet to be as level as possible before proceeding.

Figure 2: Use the **Step 1 Hardware Kit** to attach the Base to the Rear Linkage.

Hand tighten 4 × Bolts with 4 × Washers on the Base Joint.

DO NOT fully tighten the bolts with the wrench at this time. This will be done later in the assembly process.

Figure 3: Align the Base Fork with the Rear Linkage Arm by first rotating the Base Fork and then rotating the Rear Linkage Arm on top so they connect at the Fork Joint.

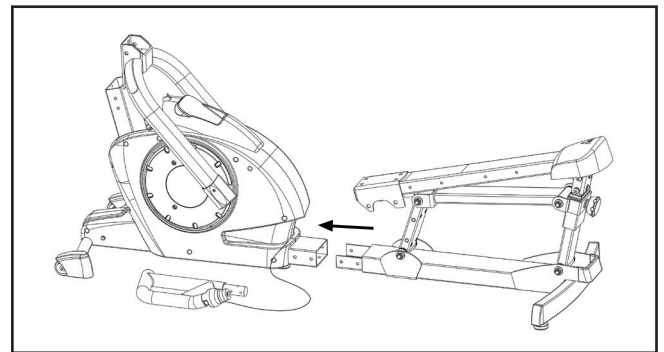

Figure 1

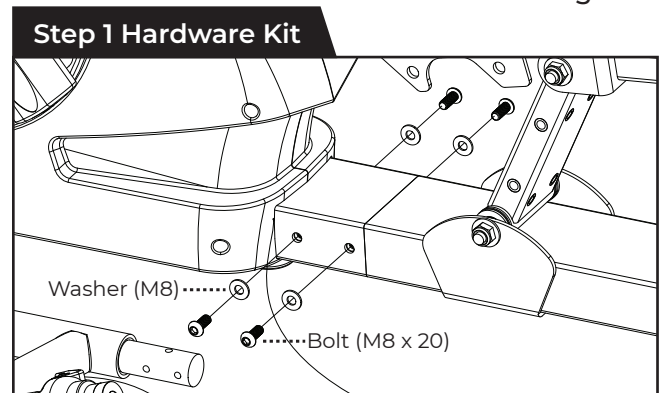

Figure 2

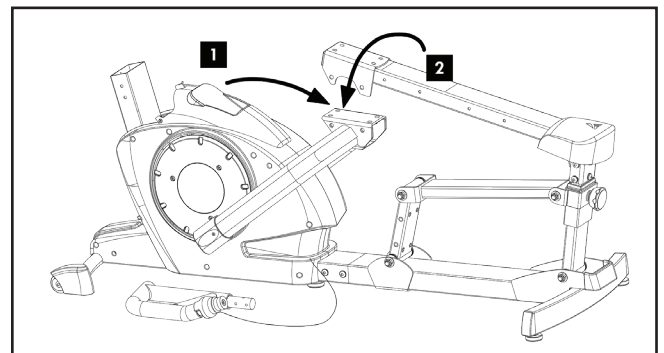

Figure 3

Step 2 Hardware Kit

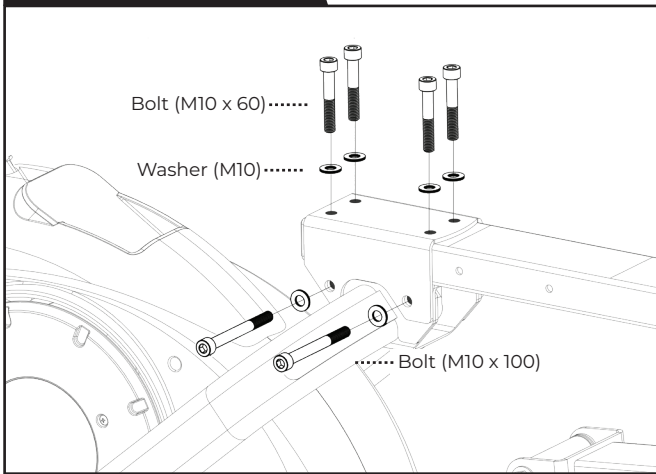

Figure 4

Figure 4: Use the **Step 2 Hardware Kit** to attach the Base Fork to the Rear Linkage Arm at the Fork Joint.

Hand tighten 6 × Bolts with 6 × Washers on the Fork Joint.

Proceed to fully tighten the (4) short bolts M10 x 60 with the 8mm Allen Wrench and the (2) long bolts with the M10 x 100 with the the 6mm Allen Wrench.

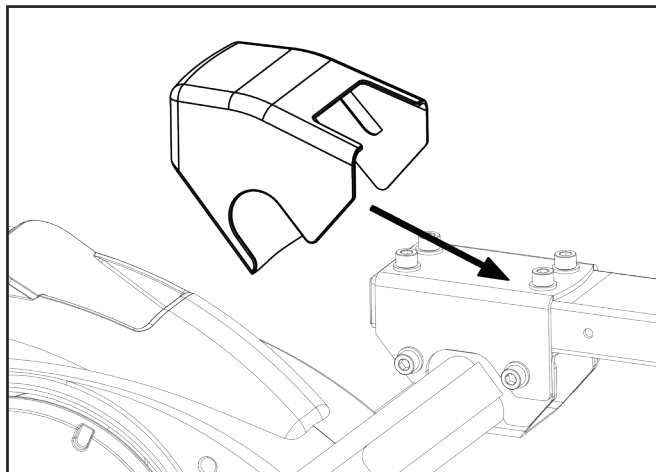

Figure 5

Figure 5: Align the Fork Joint Cover over the Fork Joint.

Step 3 Hardware Kit

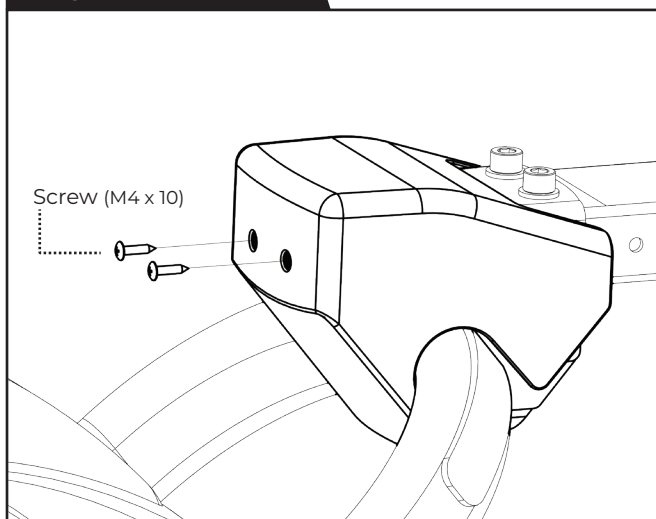

Figure 6

Figure 6: Use the **Step 3 Hardware Kit** to attach the Fork Joint Cover over the Fork Joint and fully tighten the 2 × Screws with the Screwdriver provided.

FOOT PLATFORM ASSEMBLY

IMPORTANT: Use caution to ensure the Cables on the Foot Platform and Foot Platform Joint do not get pinched or pulled while attaching the Platform Assembly.

Figure 7: Align the Foot Platform with the Base and insert it over the Foot Platform Joint.

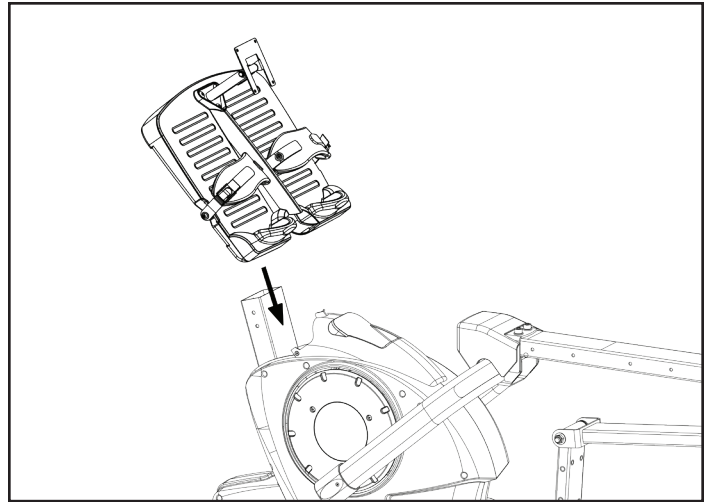

Figure 7

Figure 8: Use the **Step 4 Hardware Kit** to attach the Foot Platform to the Foot Platform Joint.

Hand tighten 6 × Bolts with 6 × Washers on the Platform Joint.

Proceed to fully tighten the bolts with the 6mm Allen Wrench.

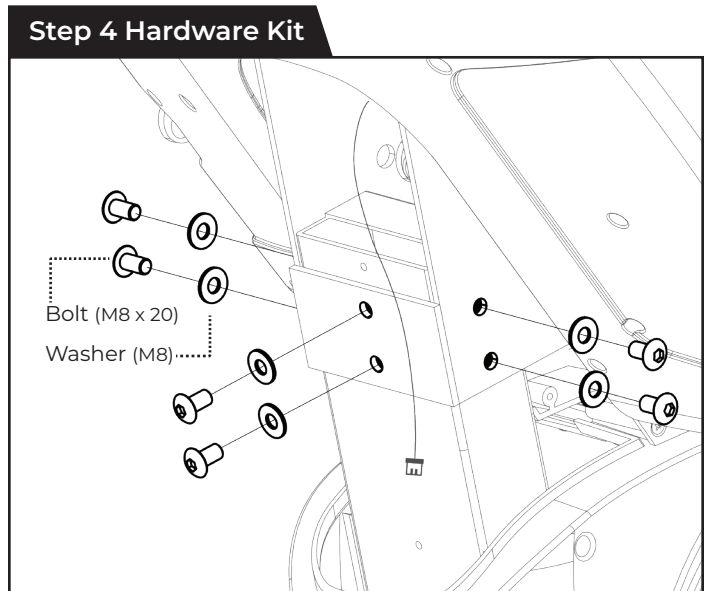

Figure 8

Figure 9: Connect the Cables at the Foot Platform Joint by snapping the two ends of the Cables together.

NOTE: DO NOT push excess or loose wire down into other parts of the machine. This can cause tangling and damage the wire.

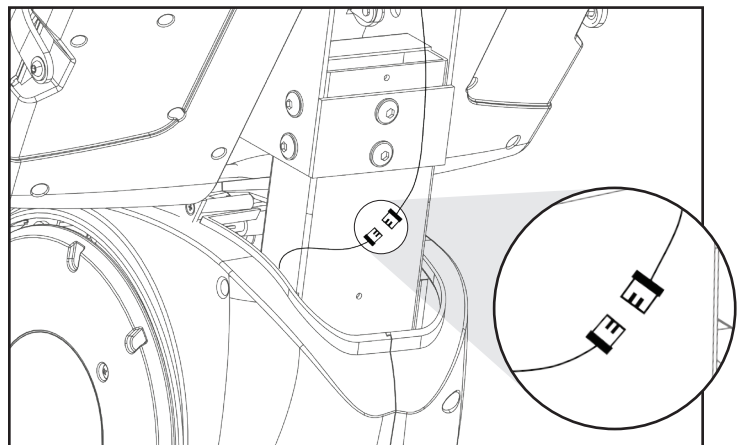

Figure 9

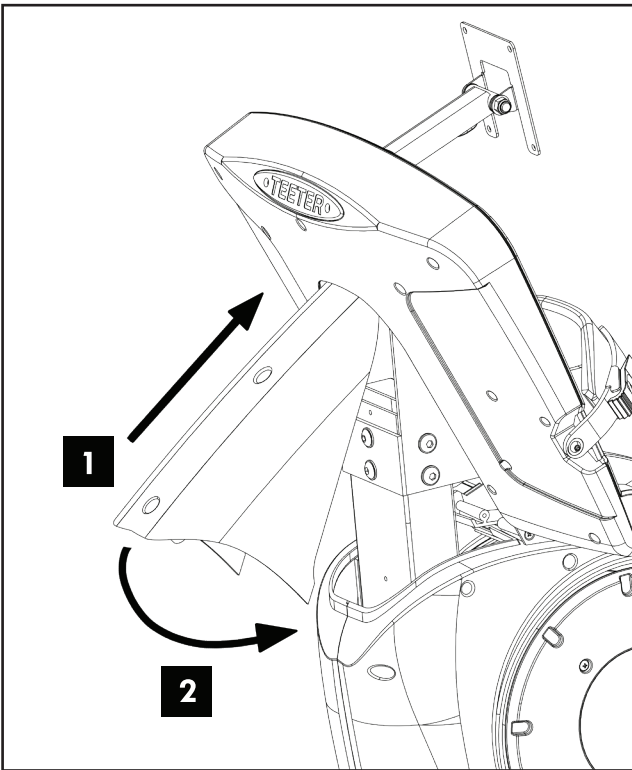

Figure 10

IMPORTANT: Use caution to ensure the Cable does not get pinched or pulled while attaching the Foot Platform Joint Cover.

Figure 10: Slide the top of Foot Platform Joint Cover so that it fits inside the front of the Foot Platform and then rotate the bottom of the Foot Platform Joint Cover into place so that it rests on top of the Base, enclosing the Foot Platform Joint.

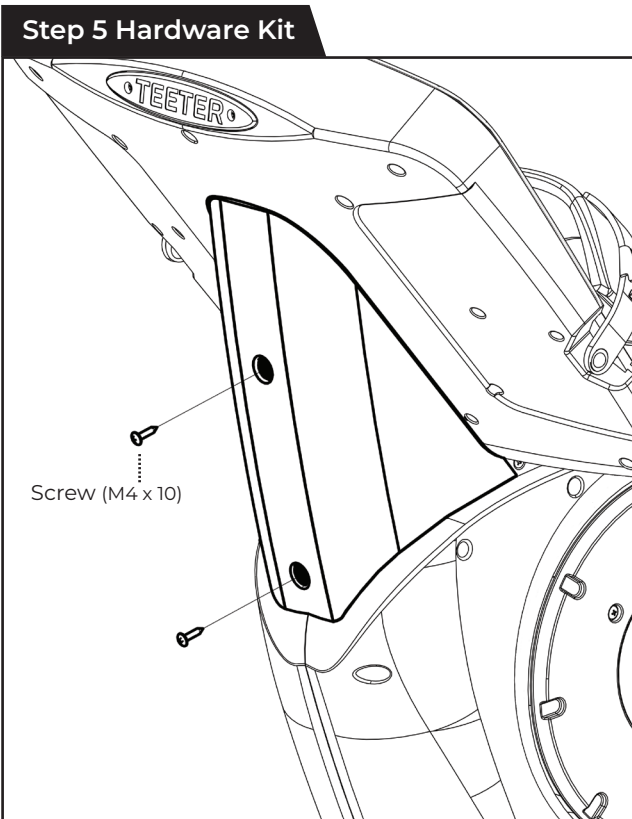

Figure 11

Figure 11: Use the **Step 5 Hardware Kit** to attach the Foot Platform Joint Cover over the Foot Platform Joint and fully tighten 2 × Screws with the Screwdriver provided.

FINISH BASE ASSEMBLY

⚠ CAUTION

Use caution to avoid injury or tipping when lifting heavy objects.

Figure 12: To have better access for the next assembly steps, position the Power10 to rest on its front side by lifting up on the Rear Handle and rotating on the Transport Wheels until the Foot Platform is resting on the ground.

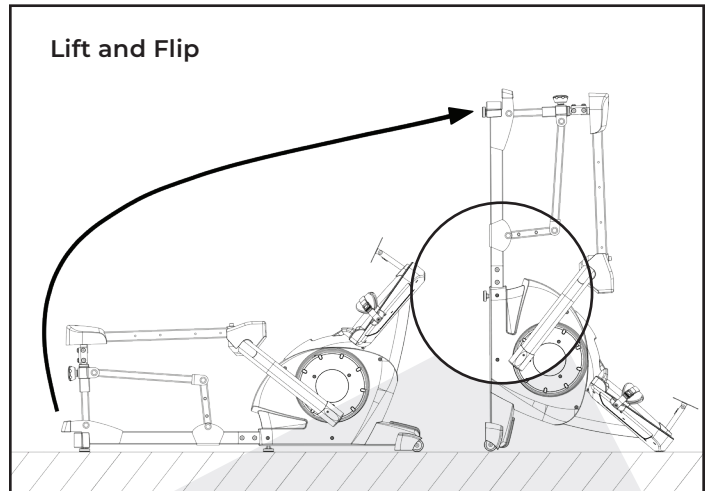

Figure 12

Figure 13: Use the **Step 6 Hardware Kit** to finish assembling the Base Joint.

Hand tighten 4 × Bolts with 4 × Washers on the Platform Joint.

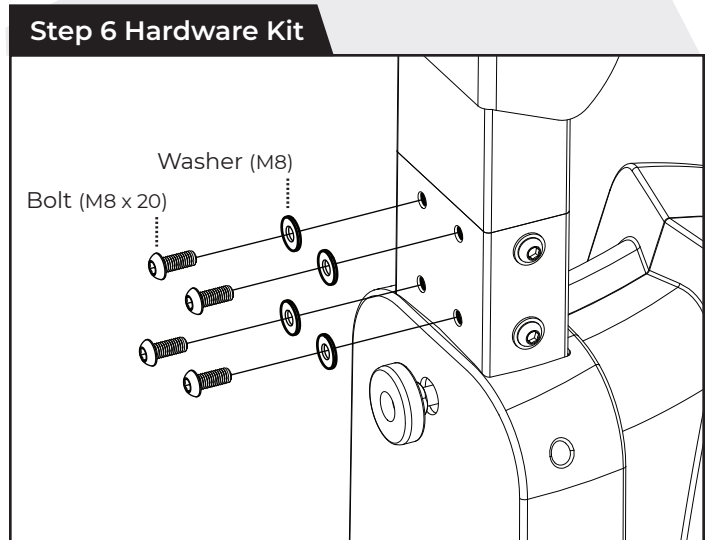

Figure 13

Figure 14: Proceed to fully tighten all 8 × Bolts on the Base Joint with the 6mm Allen Wrench.

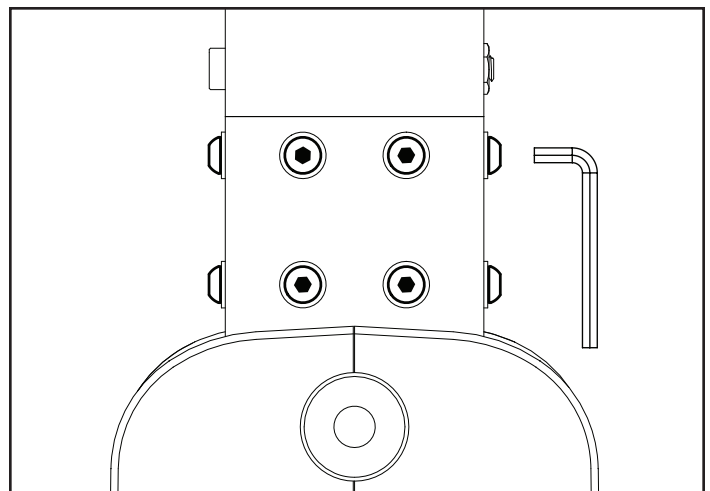

Figure 14

LOWER HANDLE ASSEMBLY

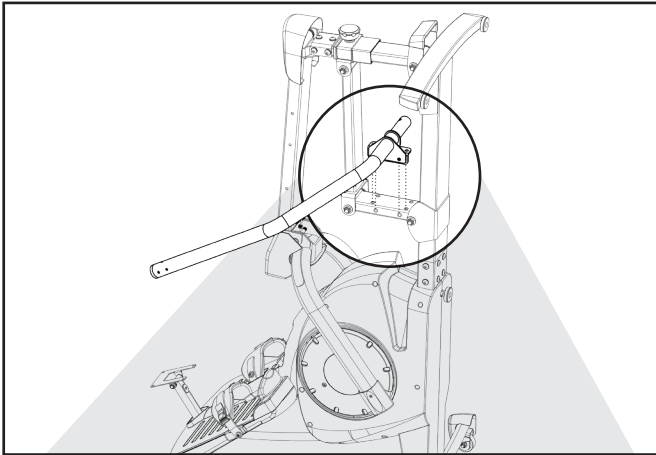

Figure 15a

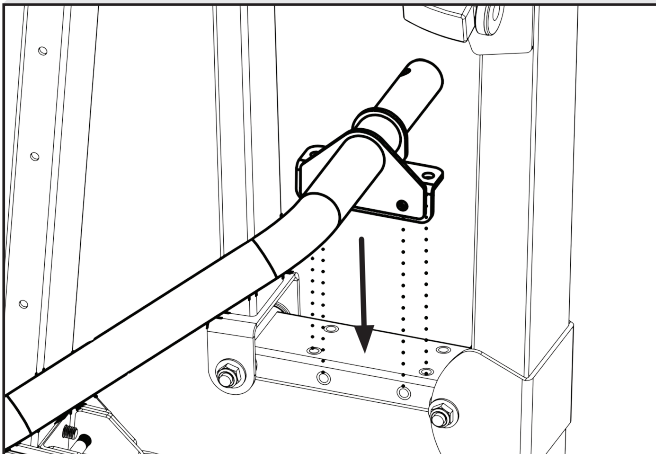

Figure 15b

Step 7 Hardware Kit

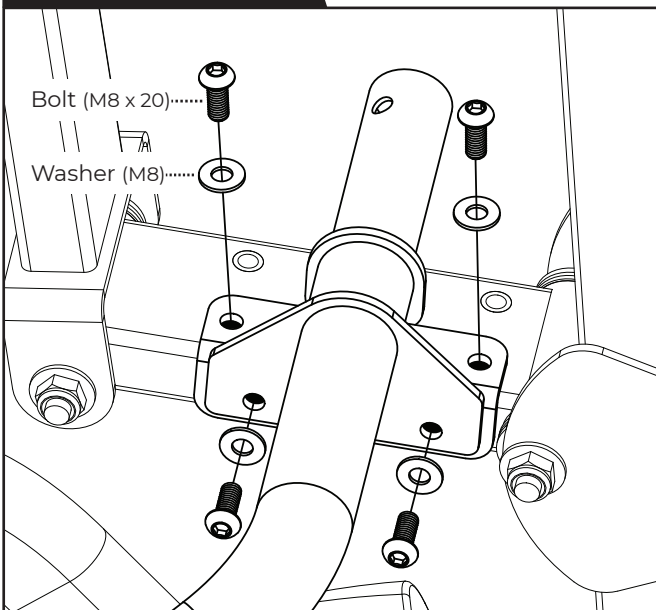

Figure 16

Figure 15a & 15b: While the Power10 remains tipped upward, align the Lower Left Handle with the Handle Support Bar on the Rear Linkage.

Figure 16: Use the **Step 7 Hardware Kit** to attach the Lower Left Handle to the Handle Support Bar.

Hand tighten 4 × Bolts with 4 × Washers through the Lower Left Handle and into the Handle Support bar.

DO NOT fully tighten the bolts with the wrench at this time. This will be done later in the assembly process.

Figure 17a & 17b: Slide the base of the Lower Right Handle over the base of the Lower Left Handle until it aligns with the Handle Support Bar.

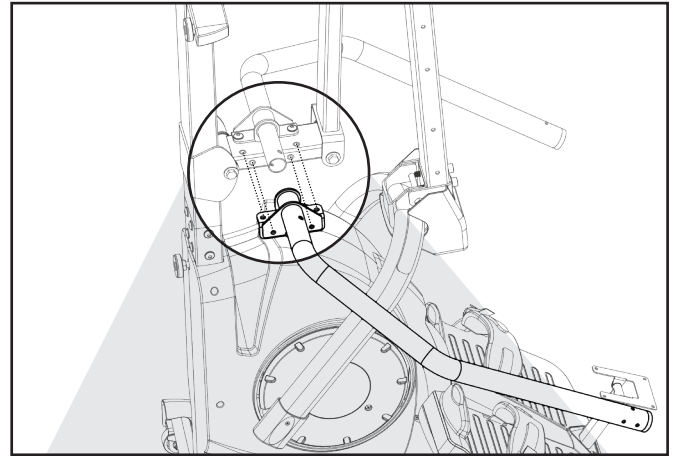

Figure 17a

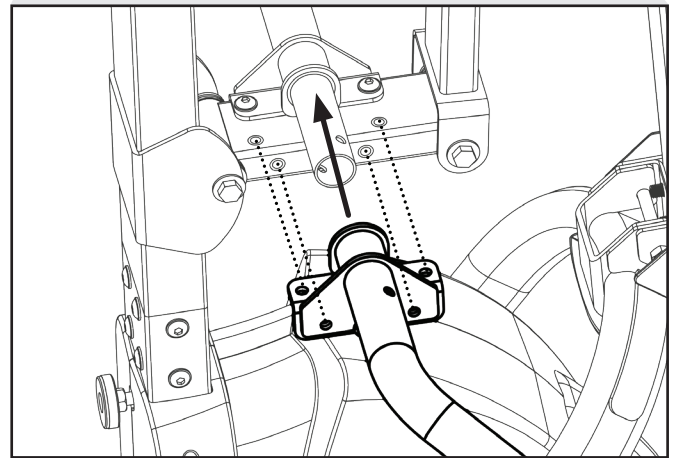

Figure 17b

Figure 18: Use the **Step 8 Hardware Kit** to attach the Lower Right Handle to the Handle Support Bar and Lower Left Handle.

Hand tighten 5 × Bolts with 5 × Washers through the Lower Right Handle and into the Handle Support Bar and Lower Left Handle.

Proceed to fully tighten all 9 × Bolts that attach the Lower Handles to the Handle Support Bar with the 6mm Allen Wrench.

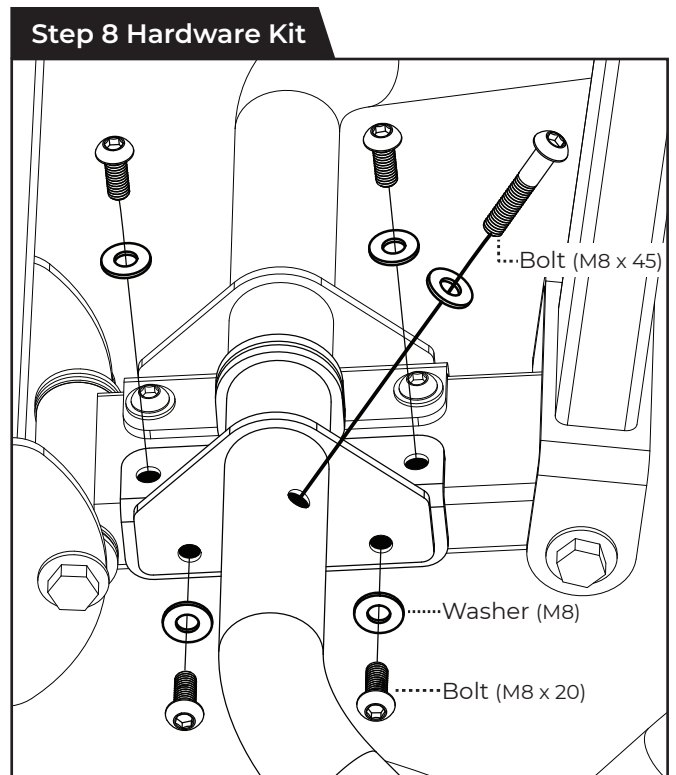

Figure 18

SEAT ASSEMBLY

Step 9A Hardware Kit

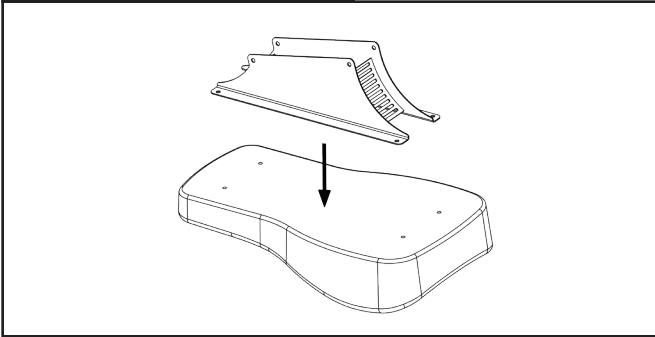

Figure 19a

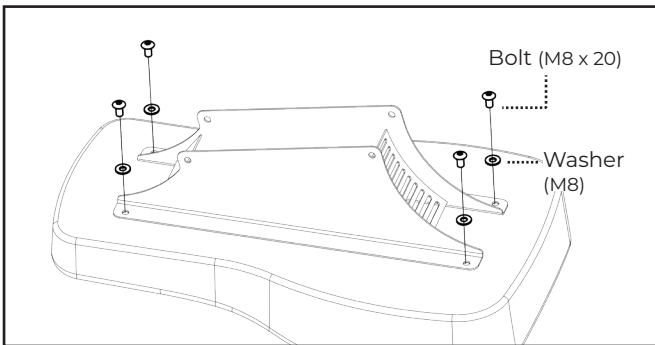

Figure 19b

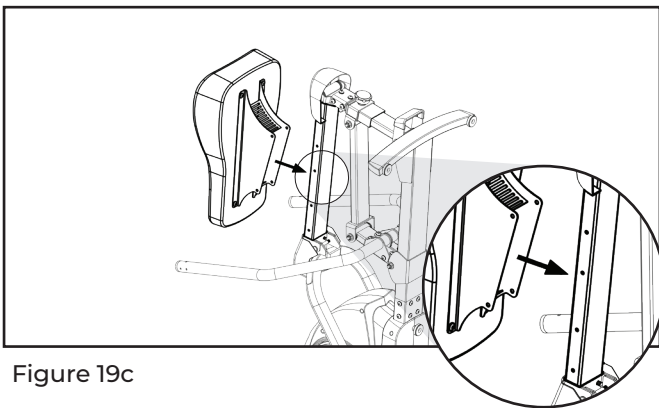

Figure 19c

Step 9B Hardware Kit

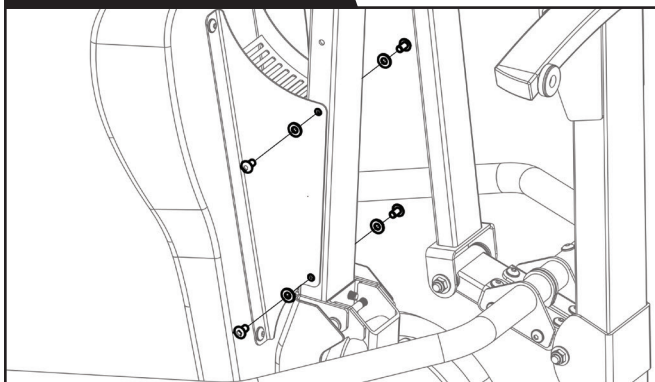

Figure 20

Figure 19a & 19b: Align holes on the flat end of the Seat Support with the holes on the base of the Seat cushion.

Use the **Step 9A Hardware Kit** to attach the Seat Support to the Seat cushion. Hand tighten 4 x Bolts with 4 x Washers through the base of the Seat Support and into the Seat cushion.

Proceed to fully tighten all 4 x Bolts with the 6mm Allen Wrench.

Figure 19c: While the Power10 remains tipped upward, align the Seat Support on the Rear Linkage.

NOTE: The Seat can be aligned toward either the front or the back of the Rear Linkage to accommodate different user heights. Align the Seat Support with either the front grooves (first and third) or back grooves (second and fourth) before proceeding. See page 18 for more details.

Figure 20: Use the **Step 9B Hardware Kit** to attach the Seat Support to the upper bar of the Rear Linkage.

Hand tighten 4 x Bolts with 4 x Washers through the Seat Support and into the Rear Linkage.

Proceed to fully tighten all 4 x Bolts with the 6mm Allen Wrench.

UPPER HANDLE ASSEMBLY

Figure 21: Return the Power10 to the in-use position by pulling down on the Rear Handle and rotating on the Transport Wheels until the Rear Linkage is resting on the ground.

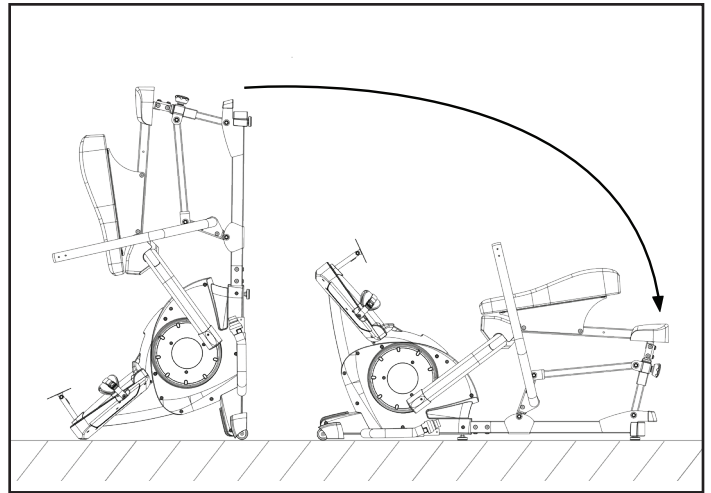

Figure 21

IMPORTANT: Use caution to ensure the Cable that attaches the Upper Left Handle to the Base does not get pinched or pulled during assembly.

Figure 22: Slide the Upper Left Handle into the top of the Lower Left Handle and align the screw holes.

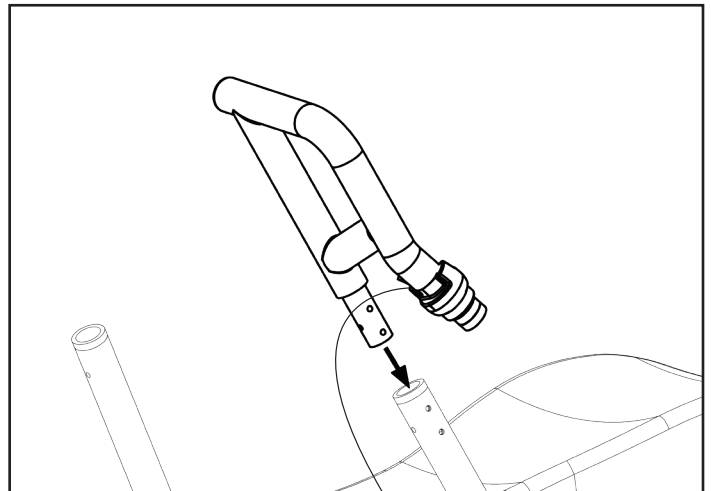

Figure 22

Figure 23: Use the **Step 10 Hardware Kit** to attach the Upper Left Handle.

Hand tighten 4 × Bolts through the Upper Left Handle and into the Lower Left Handle.

Proceed to fully tighten all 4 × Bolts with the 4mm Allen Wrench.

Step 10 Hardware Kit

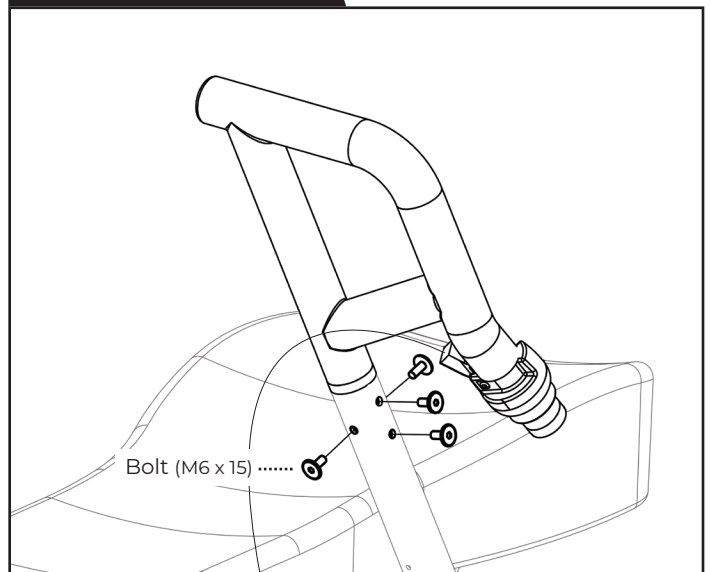

Figure 23

Step 11 Hardware Kit

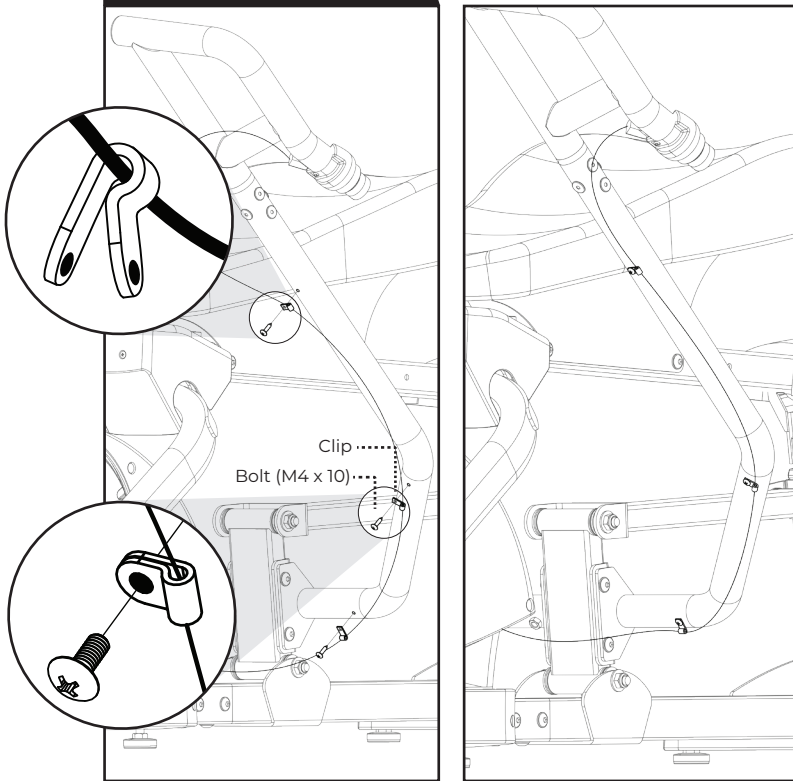

Figure 24a

Figure 24b

Figure 24a & 24b: Use the **Step 11 Hardware Kit** to attach the Cable to the Lower Left Handle.

First, open each of the 3 × Clips and insert the Cable into the rounded end of the Clips.

Position each Clip over a hole in the Lower Left Handle and hand tighten 3 × Bolts through the Clips and into the Lower Left Handle.

Proceed to fully tighten all 3 × Bolts with the Phillips Screwdriver.

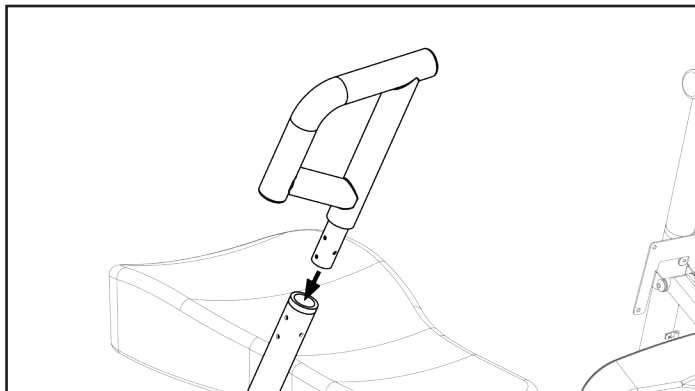

Figure 25

Figure 25: Slide the Upper Right Handle into the top of the Lower Right Handle and align the screw holes.

Step 12 Hardware Kit

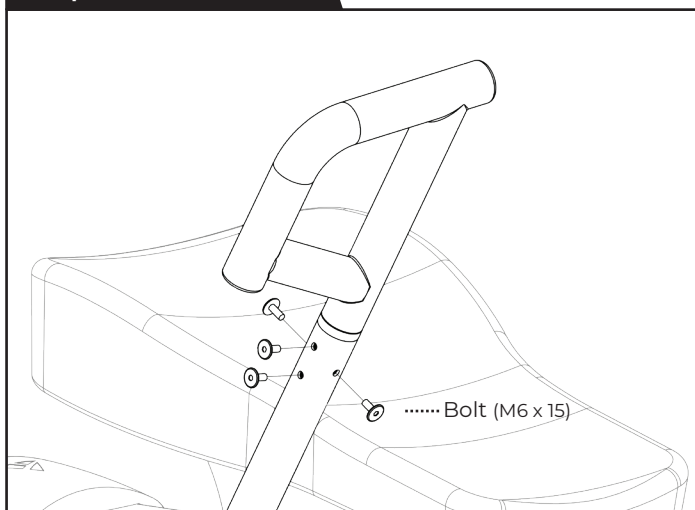

Figure 26

Figure 26: Use the **Step 12 Hardware Kit** to attach the Upper Right Handle.

Hand tighten 4 × Bolts through the Upper Right Handle and into the Lower Right Handle.

Proceed to fully tighten all 4 × Bolts with the 4mm Allen Wrench.

CONSOLE ASSEMBLY

IMPORTANT: The batteries can be installed and replaced without removing the console. However, for easier access, we recommend inserting the batteries before installing the console. Open the Battery Compartment located on the back of the console. Ensure that the battery contacts and compartment are clean. Locate the 2 × included batteries (AA 1.5 V Alkaline) and install them in the back of the Console in the Battery Compartment, noting (+) and (-) symbols.

IMPORTANT: Use caution to ensure the Sensor Wire on the Console does not get pinched or pulled during assembly.

Figure 27: Guide the Sensor Wire through the opening in the Console Support while aligning the Console.

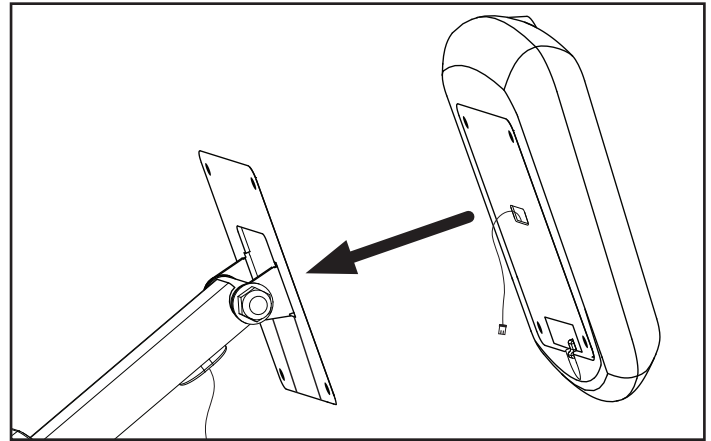

Figure 27

Figure 28: Use the **Step 13 Hardware Kit** to attach the Console.

Hand tighten 4 × Bolts through the Console and into the Console Support.

Proceed to fully tighten all 4 × Bolts with the Phillips Screwdriver.

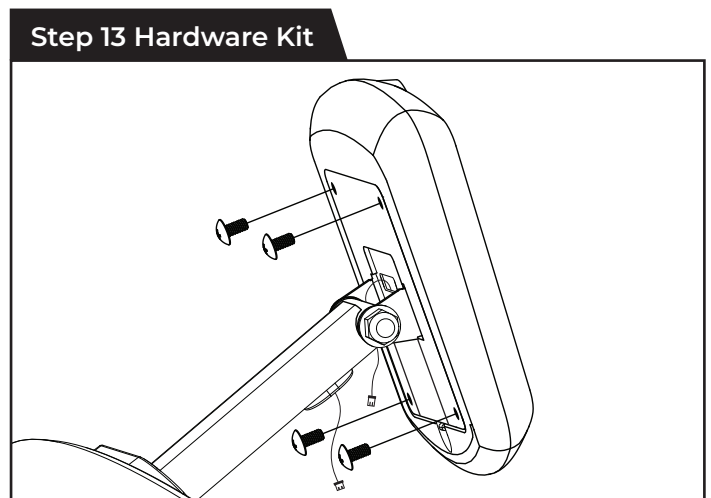

Figure 28

Figure 29: Connect the Console Cables by snapping together the two ends of the Cables.

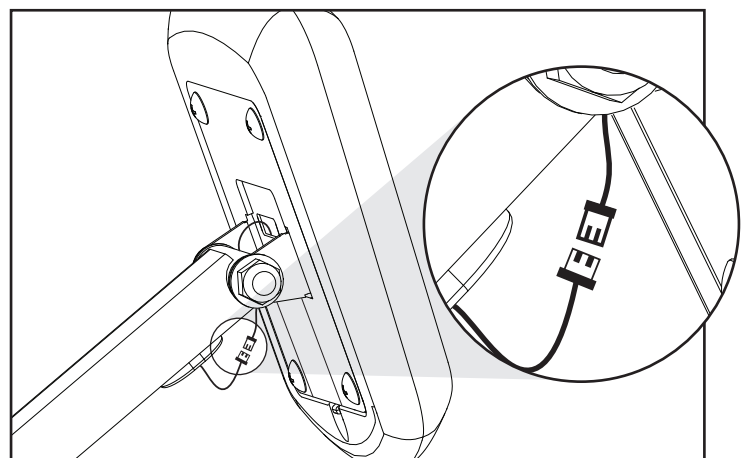
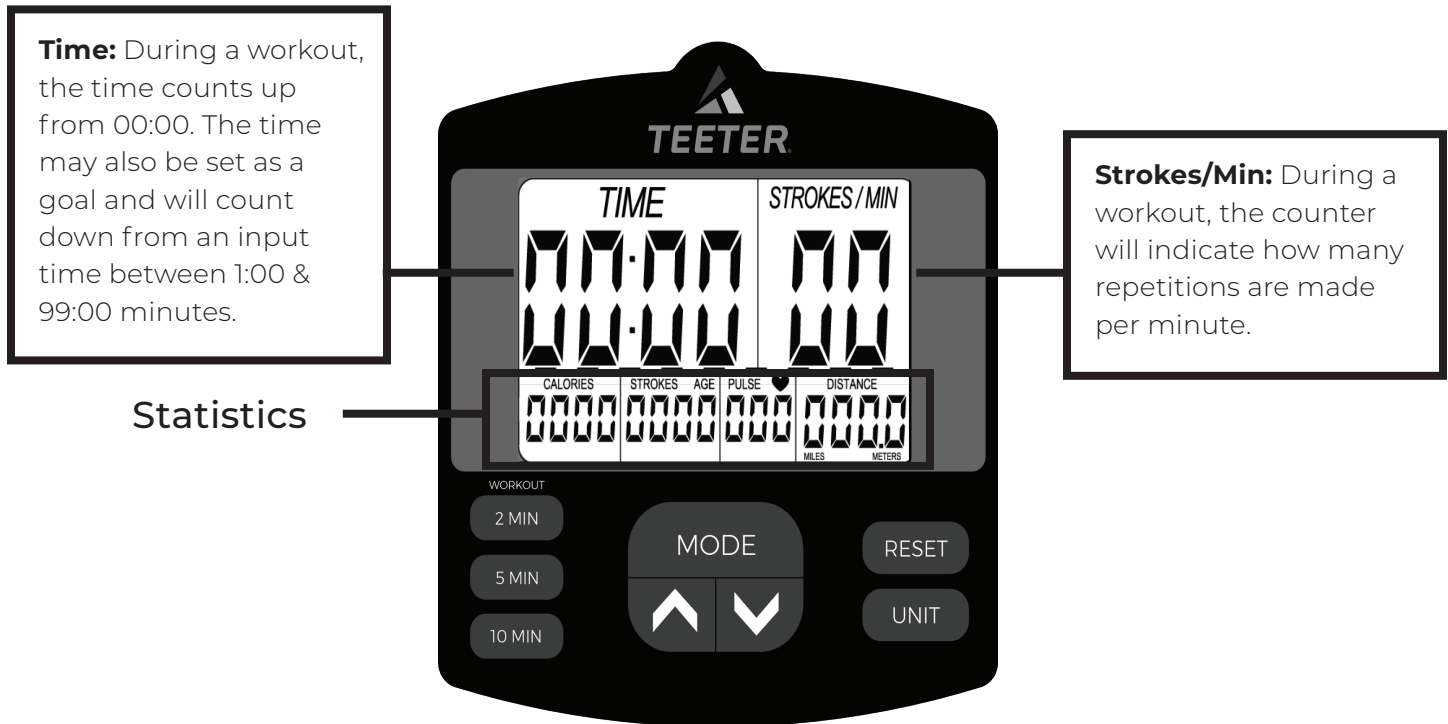

Figure 29

CONSOLE USE

The Power10 console is equipped with a non-coded wireless heart rate receiver that allows you to monitor your heart rate while wearing a compatible¹ chest strap. For optimal performance, we recommend using the included wireless heart rate monitor chest strap. The included chest strap² is compatible with the Power10 console and can also pair via Bluetooth to 3rd party apps and other Bluetooth equipped devices.



Pulse: If using a compatible¹ heart rate monitor, your heart rate will display on the Power10 console automatically when you are within range of the console. No pairing is required.

Age: You may input your age in order to adjust the calorie counter accordingly.

Entering Age:

- Press and Hold the UP + DOWN button for 2 seconds.
- AGE will begin to blink. The default is 35. Adjust the age using the arrow keys.
- After reaching your age, hit the MODE button to save this information into the computer.

Strokes: During a workout, the counter will indicate how many repetitions have been made.

Distance: Keeps track of the total distance traveled during a workout in either miles or meters. Units may be defined by pressing and holding down the UNIT button for 5 seconds.

Calories: Accumulates calorie consumption during training from 0 up to 999.9 calories. Note: For a more accurate calorie counter reading, user must connect to a heart rate monitor.

1. The Power10 console heart rate receiver is compatible with heart rate monitors that operate on the non-coded 5khz frequency. The Power10 console is not Bluetooth compatible.

2. The included chest strap wirelessly transmits your heart rate to the Power10 console over the 5khz frequency when within range. The included strap also offers Bluetooth connectivity allowing you to pair the chest strap with other 3rd party devices and apps. Please refer to instructions included with the chest strap or the 3rd party app for more information on Bluetooth pairing and usage.

Buttons

2 min: During or at the start of a workout, the time will count down from 02:00 minutes.

5 min: During or at the start of a workout, the time will count down from 05:00 minutes.

10 min: During or at the start of a workout, the time will count down from 10:00 minutes.

Mode: Turns on the console. Toggles between TIME, CALORIES, and DISTANCE so users may set their own limits.

Reset: Press and hold for 3 seconds to reset the console and all values.

Unit: You can switch between miles and meters by pressing and holding the button for 4 seconds.

ADJUST LEVELING FEET

After you have fully assembled the Power10, leveling all five feet is critical before use. If the workout area you plan to use is carpeted, we recommend leveling the feet on a hard surface such as a concrete or wood floor and then moving the Power10 to the intended workout area.

If you have trouble moving the assembled Power10 through doorways, the handles can be removed or rotated in order to clear the doorway. If you need assistance, please contact Customer Service at 800-847-0143.

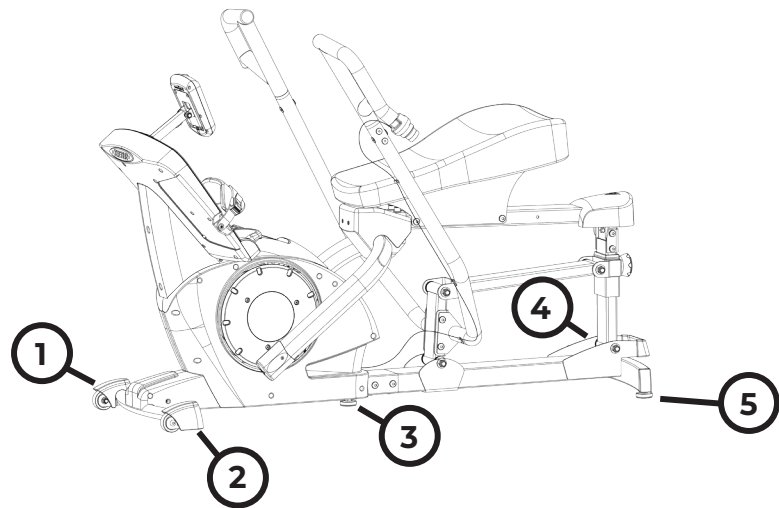

STORAGE

Lift up on the Rear Handle to tip the Power10 onto the Transport Wheels to move to the storage location.

Continue lifting up on the Rear Handle and rotating on the Transport Wheels until the Foot Platform is resting on the ground.

Ensure the Power10 is stored on a flat, stable surface near a wall, if possible.

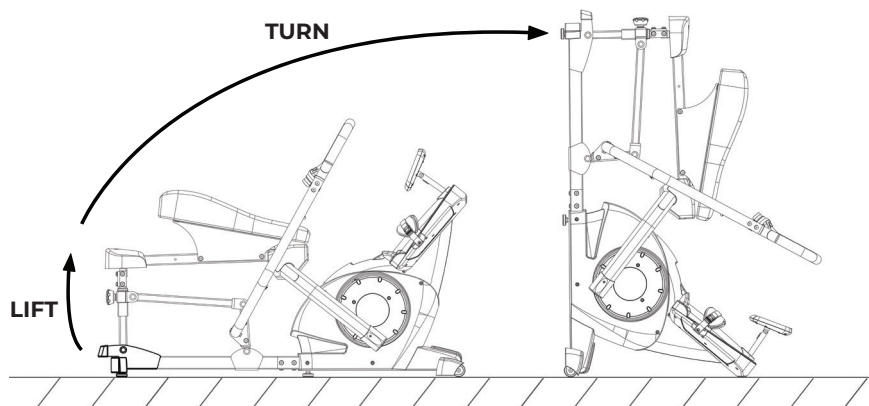

USER ADJUSTMENTS



Figure 30

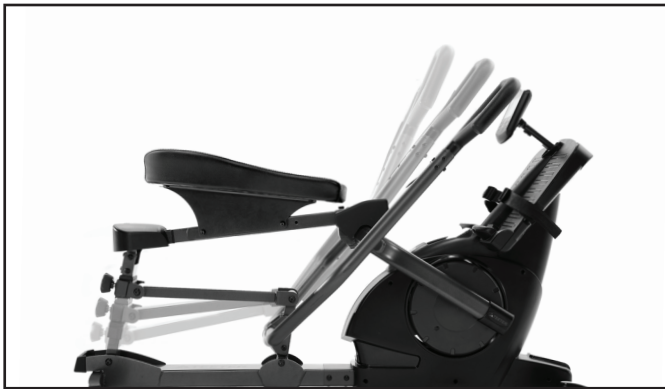

Figure 31



Figure 32



Figure 33

Seat Placement & Adjustment

Figure 30: To ensure a safe and comfortable experience, sit slightly forward on the seat, adjusting placement to allow for a slight bend in your knees at full extension. Practice proper posture by sitting straight and engaging your core. Your legs should not be locked out at full extension to avoid injury.

The Seat can be set to either a forward or backward position to accommodate users with shorter or longer legs (see Seat Assembly section, page 12).

Handle Adjustment

Figure 31: The handles can be adjusted into three (3) settings to control their depth of movement at the finish of the stroke. Once you find your seat setting, you'll want to test the handle setting to fit your body type and amount of layback (lean of the upper body) you desire. The A setting offers the greatest movement; the C setting offers the least.

Figure 32: Turn the Handle Adjustment Knob counterclockwise to loosen. Pull out on the Handle Adjustment Knob with one hand as you assist the movement of the Handle Adjustment Bar with your other hand. Release the knob and ensure it is fully engaged into a hole setting before turning it clockwise to tighten. **Note:** it is easier to slide up and down when the handles are pushed forward all the way so the rear post is straight up and down.

Resistance Adjustment

Figure 33: The Resistance Adjustment Dial can be adjusted from setting 1 (least resistance) to setting 7 (greatest resistance). Turn the dial until your desired resistance level is visible in the window. You can easily adjust your resistance during your workout at any time.

ROWING DIRECTION

The bi-directional resistance with unique elliptical motion allows you to work both sides of your body, targeting specific muscle groups in one direction while you rest and recover others. This gives you the ultimate full body workout while allowing you to maintain high intensity without muscle burnout.

Determine your direction by focusing your attention on the movement of the fork arms around the base wheel. We refer to the top of the wheel as the top of the “hill.”

REVERSE

Fork arms are moving from FRONT to REAR over the top of the hill.



Action: Similar to a traditional rowing motion. Focus on pulling with your upper body over the hill; rest on the downward momentum.

Targets: Back, biceps, rear deltoids, forearms, quads, calves.

Getting Started: Begin in the layback position, with the handles at your chest. Push and ride the momentum down the hill, then pull over the hill.

Changing Direction: As you ride the momentum down the hill, begin to slow your speed. When the fork nears the top of the wheel at the front, gently push forward to reverse direction. Ride the momentum down the hill to the rear of the wheel, then push over the hill.

FORWARD

Fork arms are moving from REAR to FRONT over the top of the hill.



Action: Opposite of a traditional rowing motion. Focus on pushing with your upper body over the hill; rest on the downward momentum.

Targets: Chest, triceps, front deltoids, hamstrings, glutes, abs

Getting Started: Begin leaning forward, with the handles at your feet. Pull and ride the momentum down the hill, then push over the hill.

Changing Direction: As you ride the momentum down the hill, begin to slow your speed. When the fork nears the top of the wheel at the rear, gently push forward to reverse direction. Ride the momentum down the hill to the front of the wheel, then pull over the hill.

MUSCLE TARGETING

CHANGE YOUR FOCUS

While you'll never be able to fully rest your legs, vary your workouts to rest some muscle groups while focusing on others. Simply power more with your arms, power more with your legs or focus on engaging your core more. This ability to change focus on the fly helps maintain your intensity while avoiding muscle fatigue.



LEGS ONLY

Amp up your lower body workout - place your hands at your sides to use only your legs to power the motion. Be sure to keep your arms close to your body to avoid impact with the moving handles.

CHANGE YOUR GRIP

Vary your upper body workout by changing your grip to target different muscle groups:

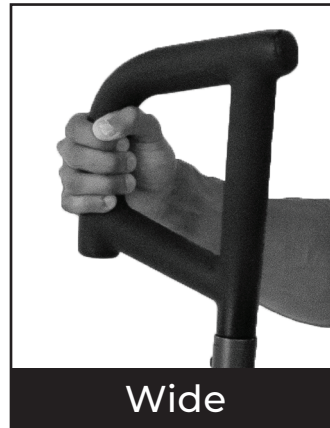
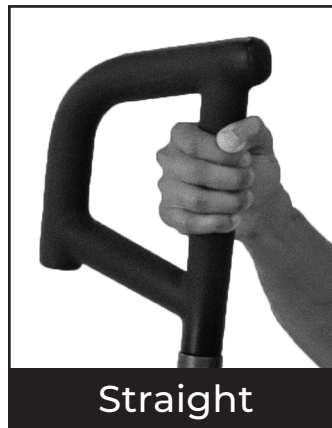
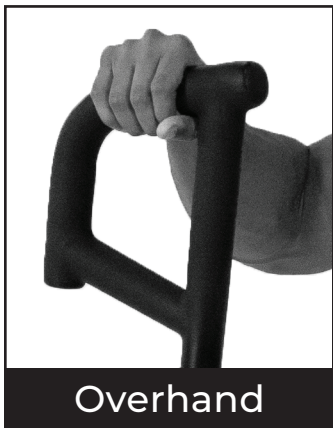

Explore More on the Teeter Video Portal

Access free video support, tips, and workouts online at teeter.com/videos or by scanning the QR code.



The Teeter warranty set forth below and on Teeter's website applies to US and Canadian customers only. For international customers, please consult your local distributor for warranty information, which will vary depending on country.



During the period starting with the day of retail purchase and continuing for one (1) year, Teeter extends to the owner a repair and replacement warranty against manufacturing defects in materials, workmanship, fabrics and padding. Teeter will repair or replace any such defect and will pay the costs of all parts, labor and transportation. If a repair or replacement is not commercially practical or cannot timely be made, then Teeter will, at the original Purchaser's option, replace with a comparable product or refund the purchase price.

Handling and transportation costs related to product warranty service only are covered by this warranty. This warranty does not cover damage resulting from improper handling, assembly, or installation, repairs made by others, accident, misuse, or abuse. Under no circumstances shall Teeter, or any other party involved in the sale of this product, have any liability for incidental or consequential damage arising from breach of an express or implied warranty on any Teeter product.

EXCEPT AS SET FORTH ABOVE, NO WARRANTY IS GIVEN WITH RESPECT TO ANY TEETER PRODUCT, AND ALL EXPRESS WARRANTIES ARE DISCLAIMED. To the extent this warranty is found not to be enforceable, it shall be deemed revised to the extent necessary to make it enforceable. This warranty and any controversy or claim arising out of this warranty or its interpretation shall be governed by the laws of the State of Washington, USA. Any controversy or claim arising out of or relating to this warranty, its interpretation, or any alleged breach thereof, which cannot be amicably settled between Teeter and the owner within sixty (60) days of written notice by the aggrieved party to the other, shall be finally settled by arbitration submitted to three (3) arbitrators selected from the panels of the arbitrators of the American Arbitration Association located closest to Teeter's principal place of business.

Some states do not allow the exclusion of incidental or consequential damage from a warranty, so the above limitation or exclusion may not apply to you. Some states do not allow limitations on how long an implied warranty lasts, so the above limitation may not apply to you. This warranty gives you specific legal rights, and you may also have other rights which may vary from state to state. This warranty is completely transferable to any and all future owners of this product, provided no alterations have been made to the product.

HOW TO SUBMIT YOUR REGISTRATION:

Step 1

Fill out this information for your own records.

 Date of Purchase

 Product & Model

Step 2

Go online to teeter.com to register your warranty.

 Dealer Name

 Serial No.

If you are unable to go online, you can request a warranty card to be mailed to you by calling Customer Service at 800-847-0143.

Please DO NOT mail this to Teeter.



LX9™ Inversion Table

The premier Teeter Inversion Table featuring the FlexTech™ 8-Pt Floating Suspension Bed that flexes as you move, Deluxe EZ-Reach™ Handle to reduce the need for bending, and so much more!



FreeStep® Recumbent Cross Trainer

Zero-impact cardio and strength! The ONLY home-use machine with patented smooth-stride technology found in high-end seated physiotherapy steppers.



FitForm™ Cable Trainer

Total body strengthening in one small package! Work your arms, legs and core with micro-adjusting resistance up to 65 lb.



T3™ Massager

Countless options for self-massage, trigger point therapy, and myofascial release to resolve tension and pain gently and naturally.

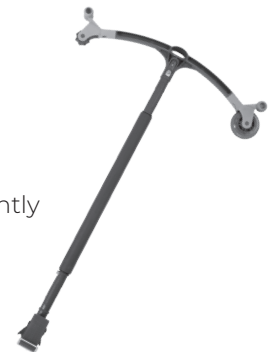

Better Back™ Foam Rollers

Prepare the body for movement, accelerate recovery, minimize muscular imbalances, and improve overall flexibility with the Teeter collection of textured Foam Rollers.



Neck Relax & Restore Duo™

Provides support of the upper neck/cervical spine for self-administered suboccipital release, a technique to reduce tension in the supporting muscles.



If you have any trouble assembling the equipment, or questions about its use, please contact customer service.

USA: 800-847-0143 or info@teeter.com

International: info@teeterintl.com

9713 233rd Ave E, Suite A

Bonney Lake, WA 98391

Toll Free: 800-847-0143

Fax: 800-847-0188

teeter.com | info@teeter.com

